

Speedcontroller YGE Opto 135

Technical data:

- The specified current is the maximum continuous full power current
- 4 to 12s LiPo, incl under voltage protection by power reduction
- Current limiting
- pluggable receiver- and telemetry cables with JST-socket
- Disconnectable under voltage detection
- Electronic speed control (Governor- mode)
- Soft start
- Active free-wheel, allowing unlimited part load operation.
- Automatic or 6 step adjustable timing
- Frequency: Automatic.
- Adjustable EMK brake
- F3A(Acro brake (brake force control infinitely adjustable)
- Speed limit: 240.000 rpm (2- Poles)
- Temperature and overload warning
- Anti- flash: decreases the closing spark.
- Basic -Programming with mode programming
- Fine adjustment and selection of telemetry log with the PC Setup
- Suitable USB-adapter optionally available
- Dimensions in mm: ca. 82 x 43,5 x 26
- Weight without / with wires: ca. 113g / 155g
- Cable diameter battery / motor: 6² / 4²

We point out that the mode-setup has to be successfully done before using the controller!

(By using VBC + NEO not necessary)

(Look at the back page)

Mode 1: V- Stabi - Gov (external Governor)

Plug the RPM-output of the controller into the rpm/ tele in-pult of the receiver or FBL (for wire assignment see additional page). Make sure that the wire of the rpm signal is parallel to the negative wire of the receiver wire. Activate the rpm mode of your FBL system.

Mode 2: Standard Governor Mode

When operating in Gov mode, the ESC can be used directly. If you want to fly different RPM's and switch them in flight, you have to start with at least 70%. Then you can switch over to different RPM's.

Mode 3: Gov.- Store

In Gov-Store you have to switch once to a high rpm over 70% with blades after programming, in order to learn in the motor parameters. The learning in happens directly after startup and you can fly. No restart necessary. Thereafter you can also start with the lowest rpm and switch in flight if you want.

The Gov. RPM regulator (Mode 2 and Mode 3) starts from 50% throttle opening. That is why we do not recommend to operate the heli under 50%.

We recommend the following throttle openings:

Hover (Low RPM)	60 ... 70%
Standard	70 ... 80%
3D	80 ... 90%

In case the headspeed is too high with the recommended throttle openings, you should choose a lower pinion or a motor with less KV. Caution! For special applications like for example scale-helicopters with high weight we recommend to set the throttle opening preferably high, to prevent unneeded heat losses.

Mode 4: Electronic gliders with brake

This mode includes all parameters for electronic gliders with brake.

Mode 5: Airplanes without brake

This mode contains all parameters for airplanes without brake.

Mode 6: Airplanes with Acro-brake (F3A brake)

This mode contains all parameters for airplanes with Acro-brake for F3A competitions.

Start-up:

After connecting the main battery you will hear 3 descending beeps. You need to connect the motor to hear the beeps; whereby the connected motor acts as a beeper. A number of beeps will follow according to the number of cells; a long beep stands for 5 cells and a short beep for one cell. Example: long...long...short...short - 5 + 5 + 1 + 1 =12 cells. If the transmitter is now in the correct stop-position, you will hear 4 ascending beeps.

- The controller is now ready- .

If the motor turns in the wrong direction, it can be reversed by exchanging 2 of the 3 motor wires.

Use only clean and tight gold connectors for the motor and battery. The 5,5mm or 6mm gold-connectors have proven to be the best choice. Exchange low-friction - or oxidized plugs and sockets. Because only tight sitting contacts will ensure a high current flow, protect the speed controller against dangerous voltage peaks and avoid disturbances.

The entire wire length, from the controller to the battery, may not exceed 30cm. If longer wires are necessary, more switch resistant additional capacitors have to be used (Ultra Low ESR). We recommend our capacitor module YGE Cap's 9. Longer motor cables can be used. Twist the three cables in order to minimise interference emission.

Attention:

Inverting battery polarity leads to severe damage and loss of warranty !

Mode Programming:

1. For safety reasons remove ALL rotor blades!
2. Switch on the transmitter and move the throttle stick to maximum (100%).
3. Connect the battery to the ESC → wait for the interval beep: ♪♪♪ ... ♪♪♪ after 20 beeps the setup menu is entered: confirmation ♪♪ .
4. Move the throttle stick to minimum and choose the mode:

♪	Vbar - gov	Mode 1
♪♪	Gov - mode	Mode 2
♪♪♪	Gov - store	Mode 3
♪♪♪♪	Glider with folding propeller and brake	Mode 4
♪♪♪♪♪	Motor plane without brake	Mode 5
♪♪♪♪♪♪	Motor plane with F3A brake	Mode 6

5. At the desired mode, move the throttle stick to maximum: confirmation ♪♪.

If no mode has been selected, the mode programming starts again with mode 1 = Vbar - gov, etc....

6. Once a mode has been selected, move the throttle stick to minimum: confirmation ♪♪.

You will hear the beeps acc to the number of cells and now the ESC is armed and ready for use.

- THE END -

PC-Software:

In the mode-programming, all parameters are set automatically to useful values. We recommend to set as less as possible in the PC-Tool. Usually it is enough to set the telemetry-settings, if necessary. For programming with the PC-Software, the optional USB-Adapter is necessary. more informations in the manual of the USB-adapter.

Autorotation (AR) and bailout:

It is important that the motor should not be switched off (0%) completely during autorotation! Otherwise, if autorotation is cancelled, a soft start will follow and due to this a possibly unwanted autorotation. The motor needs some low RPM for the bailout, therefore set the rpm very low: the helicopter should not be able to lift off. We recommend 10 ... 20% throttle opening. If set too low, the motor or ESC might be overloaded by the bailout. The bailout also might take a few seconds for spooling up, so always bail out at a safe height! As soon as the model is on the ground, the motor has to be switched off completely, otherwise there is no soft-start and bailout is active!

Lipo protection / under-voltage protection:

Because of the voltage-driven load adjustment, it is possible to fly further with low power, because the battery recovers with smaller load. However, if the voltage continues to break in, the motor will be switched off.

Active free-wheel:

The unlimited partial load capability refers to the maximum full power current of the respective ESC types.

Temperature / overload warning:

If the speed controller's temperature exceeds its limit, because of overloading or lack of cooling, after landing and/or motor stop, a warning signal is issued (3 beeps in the interval). But the motor is not switched off in flight! Only when the temperature reaches an extremely critical level, rpm will be reduced to 75% of the current power.

The partial load operation between half and nearly full power is the most difficult area for an ESC. In addition the running time becomes longer and longer with the Lipo technology. If it comes to repeated temperature warnings, better cooling should be provided or the current should be reduced.

These warnings are to be regarded as overload warnings and **not as normal operating condition**. At high temperatures the components are very stressed and this leads to a decreased service life.

You achieve better cooling not only through sufficiently dimensioned air intake, but even more efficiently through a larger air outtake, in order to avoid heat accumulation.

You achieve smaller currents by using a smaller propeller or a battery with one less cell.

Caution:

It is important to make sure that no objects are within the propeller circle when batteries are connected. The use of this speed controller is therefore allowed only in situations where damages and personal injuries are impossible. A damaged controller (e.g. broken, damaged by polarity inversion or humidity) must not be reused under any circumstances. Otherwise malfunctions or subsequent defects may arise at a later date.

The ESC should only be powered by batteries, the use from power supplies is not allowed.

Analysis of malfunctions:

- 2 Beeps/flashes: Under-voltage identification
- 3 Beeps/flashes: Temperature rise warning
- 4 Beeps/flashes: Overcurrent
- 5 Beeps/flashes: Receiver signals failed
- 6 Beeps/flashes: start up failed

The ESC has a yellow LED - status indicator light as well as a red LED light to analyze error. A flashing sequence indicates errors during operational use. After about a 1 minute successful run the error will be automatically deleted.

Connections:

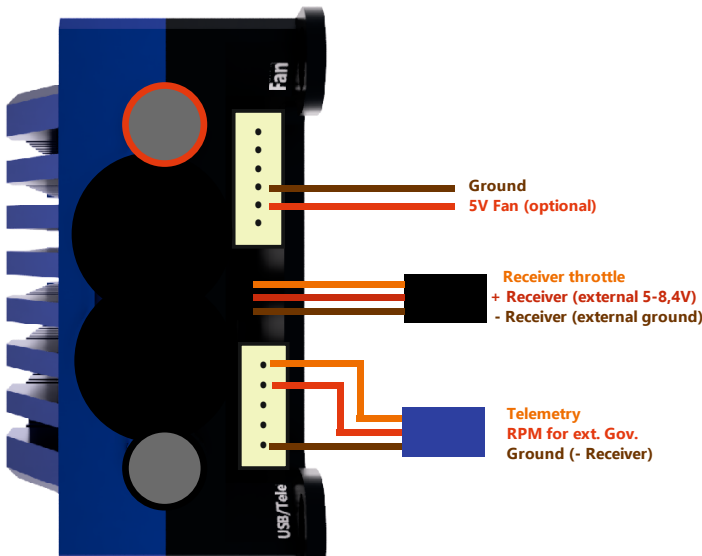

Multiplex MSBV2 Addresses:

After selecting MSBV2 as telemetry protocol in the PC-software, the addresses of the telemetry data can be changed or disabled here.

Graupner:

After selecting HoTT V4 as telemetry protocol in the PC-software, several ESC parameters can be configured in the telemetry menu of the transmitter. The max PWM will be shown as max. BEC-Temp in the HoTT telemetry, because of the small data volume in the HoTT ESC-sensor. The max PWM is important for many helicopters to adjust the range of the governor.

Connecting the ESC to the USB-Adapter:

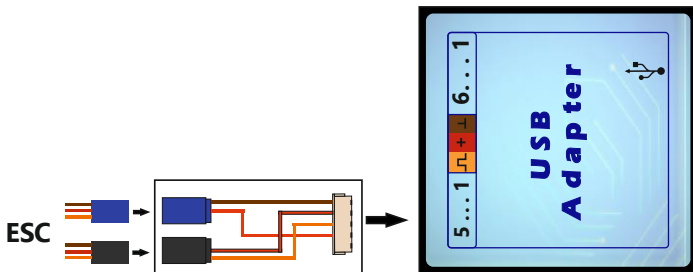

Please use the attached adaptercable for connecting the ESC with the USB-Adapter as shown above. Connect the blue connector of the ESC with the blue socket of the adaptercable, and the black connector of the ESC with the black socket of the adaptercable. Please plug the white 5-pin JST-connector into the 5-pin socket of the USB-adapter.

Mikado:

By using Vbar Control with NEO it is **not** necessary to do the mode-programming or PC-Setup. The ESC has an Auto-Detect and sets all parameters by itself after startup. Also the telemetry will be automatically set to Mikado, so you can set all parameters in the transmitter. The YGE-App has to be installed in your VBC first. This does not apply to the use with older Vbars like Mini-Vbar or Silverline.

Adapter for using Vbar-Governor and VBC-Telemetry (available separately):

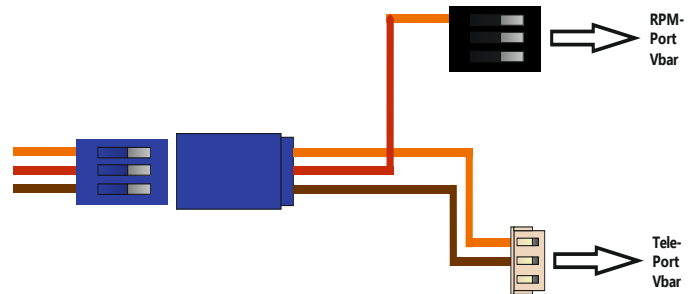

Telemetry:

The ESC sends all ESC-related data via telemetry, such as voltage, current, capacity, RPM, throttle percentage, PWM, warnings and error messages. It depends on the used receiver and transmitter, which of these data will be shown in the transmitter.

YGE (preprogrammed):

The YGE-protocol is for example for use with **YGE TexY** (Futaba, Spektrum, FrSky, Core), MSH Brain 2 or Spirit FBL.

Jeti ExBUS:

Please configure your receiver for using ExBUS (Not EX!) on the E1 or E2 channel and connect the telemetry cable (blue connector) with this channel. The telemetry in the ESC must be set to Jeti ExBUS in the PC-Software as well. After that, several ESC parameters can be configured in the JetiBox menu of the transmitter. You find these settings under "Mx" here.

Warranty:

Our warranty conditions are based on the European Statuary Warranty. Any other requirements are excluded. That applies in particular to requirements for damage or injuries compensation due to malfunction or failure. For damages to property or personal injuries and their consequences, which developed from our supply or craftsmanship, we do not take any liability, since we have no control on handling and use.

YGE - Young Generation Electronics
 Otto-Hahn-Str. 1A
 49134 Wallenhorst
 Germany

